

Model : SYNC-X8-OCS15T / OCS20T



Product Specification:

Model	SYNC-X8-OCS15T	SYNC-X8-OCS20T
Capacity	15t	20t
Division	5kg	10kg
Application	Crane	
Accuracy	OIML III	
Taring Range	100% F. S	
Max. Safe Load	125% F. S	
Overweight Alarm	110% F. S	
Power Supply	Full Seal Airtight Recharge Battery 6V8AH	
Result Steady Display	3 ~ 7 Seconds	
Display Tube	Super-Bright LED	
Net Weight	35kg	100kg
Limit Coefficient	4	
Working Temperature Range	-10°C ~ +40°C	
Remote Controller Distance	≤20m	

Product Features:

- Type of electronic crane scale with high accuracy, one side direct display measuring unit which combine load cell and power supply together
- Can be directly hung on the hook of a hoist and ensure the scale to complete the tasks of loading and weighing goods synchronously
- Remote control of tare, zero and accumulation
- Replaceable battery ensures 24hrs work
- 45mm LED display, 6V8AH rechargeable battery
- The scale body is made of strong alloy aluminium
- Can be widely used in manufacturing, fabric producing, chemical and medicine engineering, keeping grain and good in the storehouse, buying and selling of farming product etc
- Type of satisfying crane scale for modern management and high production efficiency

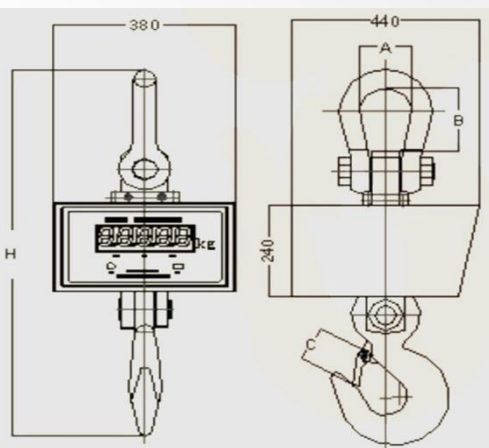
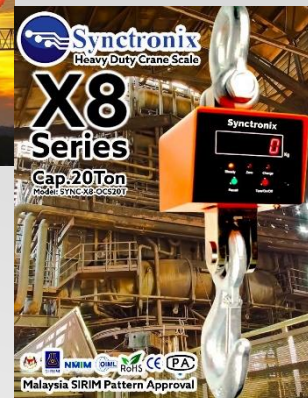

External Dimensions (mm)

Size	OCS15T	OCS20T
A	123	175
B	150	220
C	87	129
H	1010	1300

